

# EE29/EE31 Series

## Multifunctional Industrial Transmitter for Humidity / Temperature / Dew Point / Absolute Humidity...

The precise and reliable measurement of humidity in industrial processes is gaining more and more importance. The multifunctional transmitters series EE29/31 offer the ideal solution.

The result of many years of experience in humidity measurement technology for industrial applications, the EE29/31 series builds on the E+E high-quality HC series capacitive humidity sensor elements.

The optimal hardware structure for varying applications is achieved by combining various standard mechanical and electronic modules. User friendly MS Windows software tools simplify the configuration of the transmitter, the data recording, visualization and processing.

The measured values are available on two freely configurable and scaleable analogue outputs and on the serial RS232 interface. With an optional RS485 module or Ethernet module up to 32 EE31 transmitters can be connected to a network and one single PC interface allowing easy remote monitoring.

Two freely configurable optional alarm outputs can be set by software. The measured data and the corresponding MIN/MAX values can be viewed on the optional LC display.

Other features especially tailored for harsh industrial applications are the new housing concept consisting of three modules, the easy on-site adjustment and calibration, and the interchangeable sensor option. These features allow for very fast and easy servicing of the transmitter.

By selecting a suitable housing version the EE29/EE31 series can be used for the entire range of humidity measurement applications:

- Model A for wall mounting
- Model B for duct mounting
- Model D with remote sensing probe for measurements in the extended temperature range  $-40...180^{\circ}\text{C}$  ( $-40...356^{\circ}\text{F}$ ).
- Model E with remote sensing probe for pressure tight applications between  $0.01...15$  bar ( $0.15...218$ psi).
- Model H (EE31 only) with remote miniature probe for concealed mounting (e.g. in museums) or in tight spaces.



**Model A**



**Model B**



**Model D / E**



**Model H**

## Product comparison EE29 - EE31

Functions	Comment	EE29	EE31
Measurement of relative humidity and temperature		✓	✓
two freely scaleable and configurable analogue outputs		✓	✓
6 basic hardware configurations		✓	✓
Remote sensing probe up to 20m (65.6ft)		✓	✓
On-site adjustment for relative humidity and temperature		✓	✓
LED indication of transmitter status		✓	✓
RS232 for transmitter configuration via PC		✓	✓
Configuration software	standard supply	✓	✓
Alternating display with MIN/MAX indication	optional	✓	✓
two freely configurable alarm outputs	optional	✓	✓
Interchangeable sensor cable	optional	✓	✓
Sensor protection (coating)	optional	✓	✓
Plug connection	optional	✓	✓
Calculated values $h$ , $r$ , $d_v$ , $T_w$ , $T_d$ , $T_f$ , $e$			✓
Digital data output via RS232 interface			✓
Digital data output via RS485 interface	optional		✓
Network of up to 32 instruments via RS485 bus	optional		✓
Ethernet interface for networking and remote monitoring	optional		✓
Data logging and analysis PC software	optional		✓

### EE31 - Network with up to 32 transmitters

Up to 32 EE31 transmitters can be connected in a RS-485 bus system to a single PC interface.

The measured and calculated data is stored in a PC database which is available for further processing by using the E+E datalogging and analysis software.

The data base can also be stored in ASCII format or in a database with ODBC interface.

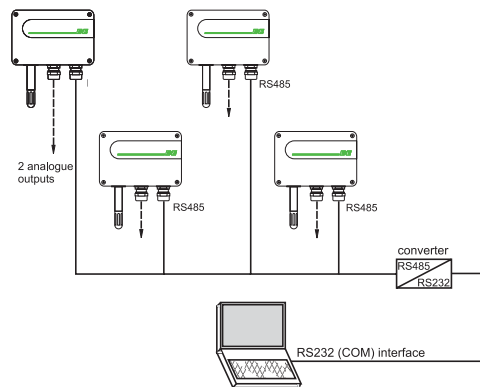

### EE31 - Ethernet interface

EE31 transmitters can be connected through a standard Ethernet-port for easy remote monitoring (ordering code E). The software-tools are in the standard scope of supply.

### Software Tools

The following software tools are available for the EE29/31 series:

	EE29	EE31
Configuration Software (standard supply)	✓	✓
datalogging and analysis Software (optional)		✓

#### Configuration Software:

The Configuration Software is used for:

- flexible, easy and fast setup of the analogue and alarm outputs.
- adjustment of the humidity and temperature outputs.
- exchange of the sensing probe or of the sensors.

#### Datalogging and Analysis Software:

This user friendly software tool is a great help for easy data analysis in graphical or spreadsheet format on a PC as well as for data and alarms management by e-mail or SMS.

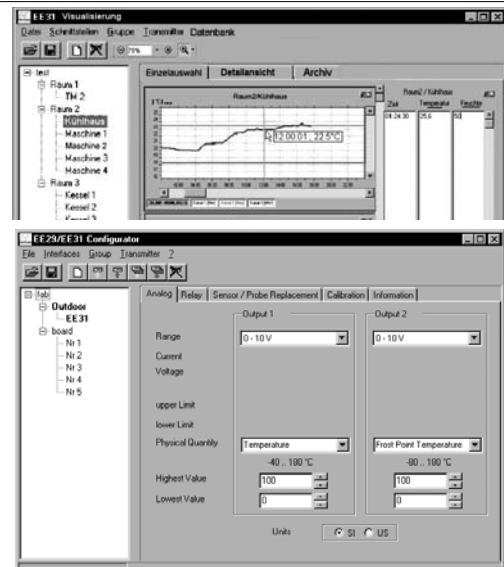

## Easy calibration and adjustment of the transmitter

The modular housing of the EE29/EE31 enables a fast and easy on-site adjustment and calibration. Using the optional extension cable one can adjust or calibrate the entire measurement loop without interrupting the measurement. No need for time-consuming dismounting and wiring of the instrument. This feature makes the EE29/31 series suitable for use in regulatory environments (e.g. FDA, GAMP).

The adjustment of humidity and temperature (2 points or 1 point) is performed either with a simple routine using two push buttons on the printed circuit board or with the configuration software.

## 2 Status LEDs

Two status LEDs on the printed circuit board indicate the transmitter status and eventual errors, especially useful during installation or service operations.

## Sensor Coating

Operation in heavily polluted and/or corrosive environments is typical for many industrial processes and can lead to drift or damage of the humidity sensor and thus to false measured values. The unique protective coating developed by E+E for the sensing probe brings a significant improvement on the long-term stability of the transmitter in very dirty and aggressive environments. (ordering code: HC01)

## Integrated Display

The actual measured and calculated values as well as the corresponding Min/Max values can be indicated on an optional display. The physical quantity to be displayed is chosen with the push buttons on the housing. (ordering code: D05)



## Interchangeable sensing probe

The interchangeable sensing probe with plug connection can be easily exchanged in the versions D and E. The installation of the probe cable (up to 20m / 65ft) is significantly simplified and can be installed prior to fitting the transmitter. (ordering code: P01)



## Alarm outputs

An optional alarm module with 2 relay outputs is available for control and alarm purposes. The selection of the physical quantity for the relay outputs and the setting of threshold and hysteresis can be easily made with the configuration software included in the standard scope of supply.

## Integrated power supply

A power supply, integrated in the back module of the housing, can be ordered optionally (100...240V AC, 50/60Hz; ordering code V01). The power supply V01 is available for both polycarbonate and metal housing and comes standard with two plugs for supply and outputs to allow an easy connection.



## Connection versions

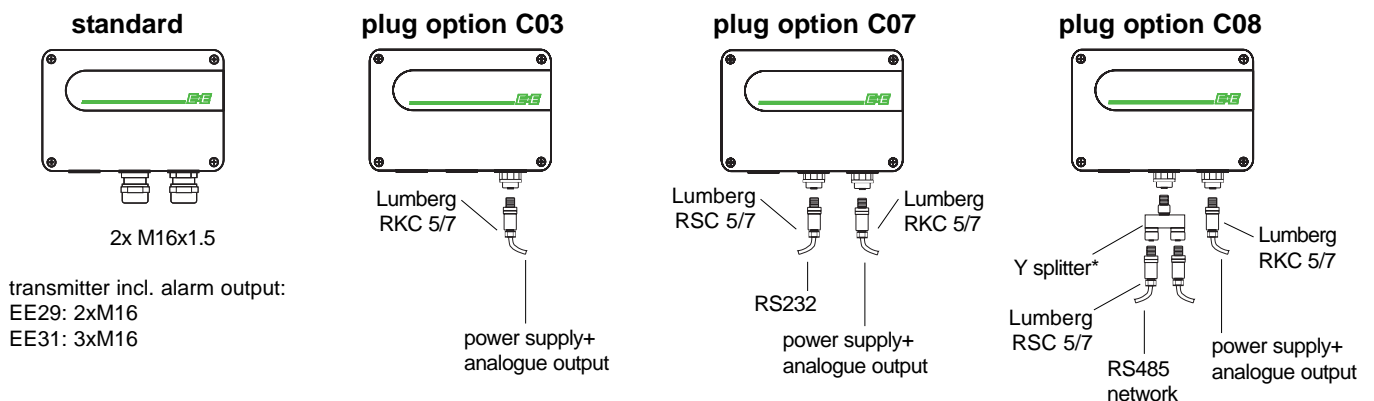

\* Siemens 6ES7 194-1KA01-0XA0

Dimensions in mm

**Housing:**

polycarbonate housing

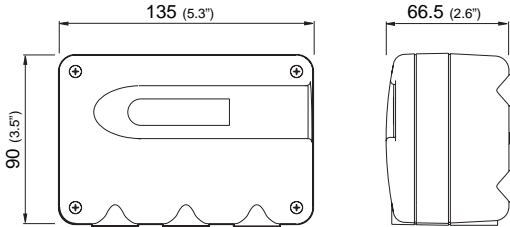

metal housing

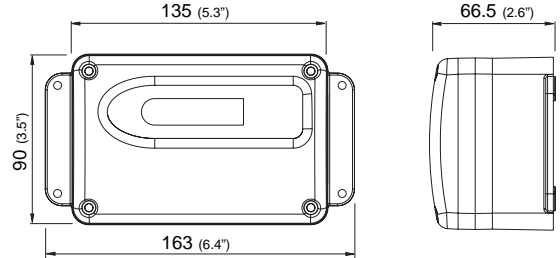

For use in harsh industrial environments all models of the EE29/31 are available in a robust metal housing. The very smooth surface and the rounded outlines allow for the use in clean rooms as well.

**Models:**

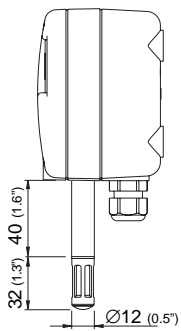

**EE29-xAx**  
**EE31-xAx**  
**Wall mounting**  
 Probe material: PC

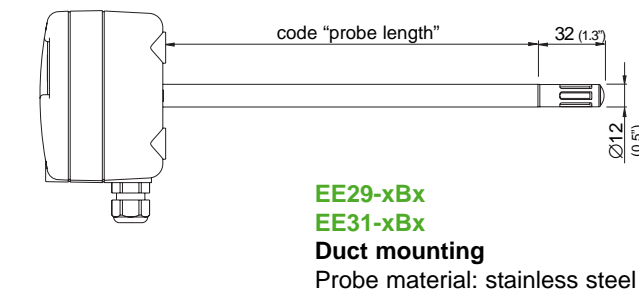

**EE29-xBx**  
**EE31-xBx**  
**Duct mounting**  
 Probe material: stainless steel

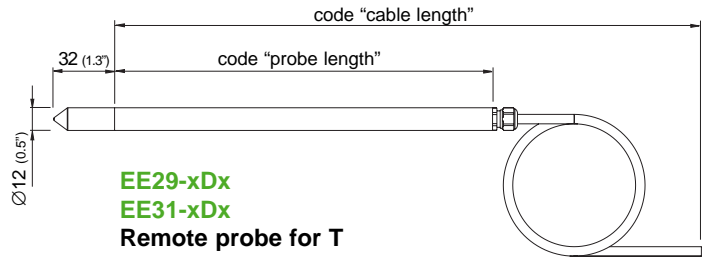

**EE29-xDx**  
**EE31-xDx**  
**Remote probe for T**  
**up to 180°C (356°F)**  
 Probe material: stainless steel

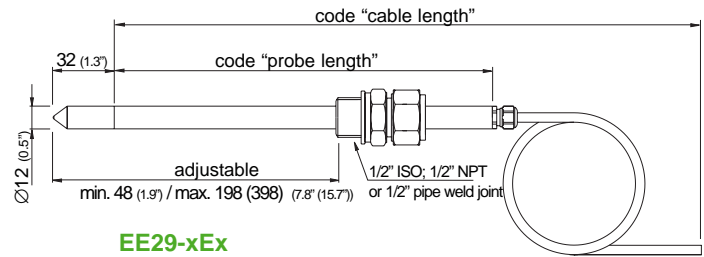

**EE29-xEx**  
**EE31-xEx**  
**Pressure tight probe**  
**up to 15bar (218psi)**  
 Probe material: stainless steel

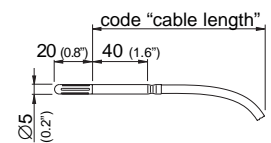

**EE31-xHx**  
**Remote miniature probe**  
 Probe material: stainless steel

## Technical Data EE31

### Measurement values

#### Relative humidity

Humidity sensor <sup>1)</sup>	HC1000-400 / HC105	
Working range <sup>1)</sup>	0...100% RH	
Accuracy <sup>2)</sup> (including hysteresis, non-linearity and repeatability, traceable to intern. standards, administrated by NIST, PTB, BEV...)		
-15...40°C (5...104°F) <90% RH	± (1.3 + 0.3%*mv) % RH	
-15...40°C (5...104°F) >90% RH	± 2.3% RH	
-25...70°C (-13...158°F)	± (1.4 + 1%*mv) % RH	
-40...180°C (-40...356°F)	± (1.5 + 1.5%*mv) % RH	
Temperature dependence of electronics	typ. ± 0.01% RH/°C (0.0055% RH/°F)	
Response time with metal grid filter at 20°C / t <sub>90</sub>	< 15s	

#### Temperature

Temperature sensor element	EE31-xA/B/D/Ex	Pt1000 (Tolerance class A, DIN EN 60751)
	EE31-xHx	Pt1000 (Tolerance class B, DIN EN 60751)
Working range sensing head	EE31-xAx -40...60°C (-40...140°F)	EE31-xEx -40...180°C (-40...356°F)
	EE31-xBx -40...80°C (-40...176°F)	EE31-xHx -40...80°C (-40...176°F)
	EE31-xDx -40...180°C (-40...356°F)	

#### Accuracy (typ.)

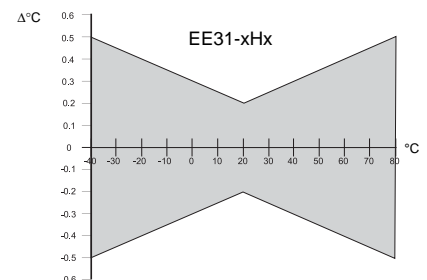
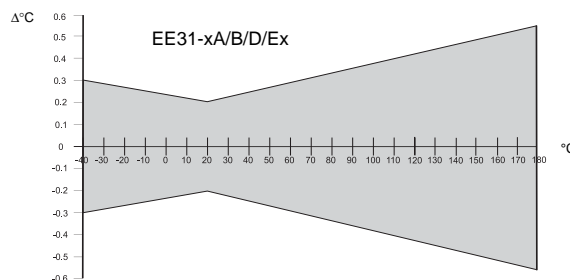

Temperature dependence of electronics typ. ± 0.005°C/°C

### Outputs<sup>2)</sup>

Two freely selectable and scaleable analogue outputs	0 - 5V	-1mA < I <sub>L</sub> < 1mA
0...100% RH / xx...yy°C respectively	0 - 10V	-1mA < I <sub>L</sub> < 1mA
	4 - 20mA	R <sub>L</sub> < 500 Ohm
	0 - 20mA	R <sub>L</sub> < 500 Ohm

#### Serial interface

RS232C  
RS485 optional

### Max. adjustable measurement range<sup>2)3)</sup>

		from	up to			units
			EE31-A	EE31-B, H	EE31-D, E	
Humidity	RH	0	100	100	100	% RH
Temperature	T	-40 (-40)	60 (140)	80 (176)	180 (356)	degC (°F)
Dew-point temperature	Td	-80 (-112)	60 (140)	80 (176)	100 (212)	degC (°F)
Frost-point temperature	Tf	-80 (-112)	0 (32)	0 (32)	0 (32)	degC (°F)
Wet-bulb temperature	Tw	0 (32)	60 (140)	80 (176)	100 (212)	degC (°F)
Water vapour partial pressure	e	0 (0)	200 (3)	500 (7.5)	1100 (15)	mbar (psi)
Mixture ratio	r	0 (0)	425 (2900)	999 (9999)	999 (9999)	g/kg (gr/lb)
Absolute humidity	dv	0 (0)	150 (60)	300 (120)	700 (300)	g/m <sup>3</sup> (gr/f <sup>3</sup> )
Specific enthalpy	h	0 (0)	400 (50000)	1000 (375000)	2800 (999999)	kJ/kg (lbf/lb)

### General

Supply voltage	SELV 8...35V DC SELV 12...30V AC	SELV = Safety Extra Low Voltage (optional 100...240V AC, 50/60Hz)
Current consumption - 2x voltage output - 2x current output	for 24V DC/AC: typ. 40mA typ. 80mA	
Pressure range for pressure tight probe	0.01...15bar (0.15...218psi)	
System requirements for software	WINDOWS 98 or later; serial interface	
Housing / protection class	PC or AI Si 9 Cu 3 / IP65; Nema 4	
Cable gland	M16 x 1.5 cable Ø 4.5 - 10 mm (0.18 - 0.39")	
Electrical connection	screw terminals up to max. 1.5mm <sup>2</sup> (AWG 16)	
Working and storage temperature range of electronics	-40...60°C (-40...140°F) -20...50°C (-4...122°F) - housing with display	
Electromagnetic compatibility according to	EN61000-6-2 EN61000-6-3 EN61326-1+A1+A2	ICES-003 ClassB FCC Part15 ClassB

<sup>1)</sup> Refer to the working range of the humidity sensor.

<sup>2)</sup> Can be easily changed by software.

<sup>3)</sup> Refer to accuracies of calculated values (page 140)

\*) The accuracy statement includes the uncertainty of the factory calibration with an enhancement factor k=2 (2-times standard deviation). The accuracy was calculated in accordance with EA-4/02 and with regard to GUM (Guide to the Expression of Uncertainty in Measurement).

## Technical Data EE29

### Measurement values

#### Relative humidity

Humidity sensor <sup>1)</sup>	HC1000-400	
Working range <sup>1)</sup>	0...100% RH	
Accuracy <sup>2)</sup> (including hysteresis, non-linearity and repeatability, traceable to intern. standards, administrated by NIST, PTB, BEV...)		
-15...40°C (5...104°F) <90% RH	± (1.3 + 0.3%*mv) % RH	
-15...40°C (5...104°F) >90% RH	± 2.3% RH	
-25...70°C (-13...158°F)	± (1.4 + 1%*mv) % RH	
-40...180°C (-40...356°F)	± (1.5 + 1.5%*mv) % RH	
Temperature dependence of electronics	typ. ± 0.01% RH / °C	(0.0055% RH / °F)
Response time with metal grid filter at 20°C / t <sub>90</sub>	< 15s	

#### Temperature

Temperature sensor element	Pt1000 (Tolerance class A, DIN EN 60751)		
Working range sensing head	EE29-xAx -40...60°C (-40...140°F)	EE29-xBx -40...80°C (-40...176°F)	
	EE29-xDx -40...180°C (-40...356°F)	EE29-xEx -40...180°C (-40...356°F)	

Accuracy (typ.)

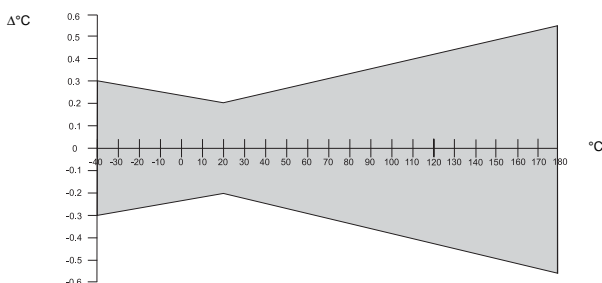

Temperature dependence of electronics typ. ± 0.005°C/°C

### Outputs<sup>2)</sup>

Two freely selectable and scaleable analogue outputs	0 - 5V	-1mA < I <sub>L</sub> < 1mA
0...100% RH / xx...yy°C respectively	0 - 10V	-1mA < I <sub>L</sub> < 1mA
	4 - 20mA	R <sub>L</sub> < 500 Ohm
	0 - 20mA	R <sub>L</sub> < 500 Ohm

### General

Supply voltage	SELV 8...35V DC	SELV = Safety Extra Low Voltage
	SELV 12...30V AC	(optional 100...240V AC, 50/60Hz)
Current consumption	for 24V DC/AC: typ. 40mA	
- 2x voltage output	typ. 80mA	
- 2x current output		
Pressure range for pressure tight sensor	0.01...15bar (0.15...218psi)	
System requirements for software	WINDOWS 98 or later; serial interface	
Housing / protection class	PC or AI Si 9 Cu 3 / IP65; Nema 4	
Cable gland	M16 x 1.5 cable Ø 4.5 - 10 mm (0.18 - 0.39")	
Electrical connection	screw terminals up to max. 1.5mm <sup>2</sup> (AWG 16)	
Sensor protection	stainless steel sintered filter, PTFE filter or metal grid filter	
Working and storage temperature range of electronics	-40...60°C (-40...140°F)	
	-20...50°C (-4...122°F) - housing with display	
Electromagnetic compatibility according to	EN61000-6-2	EN61000-6-3 ICES-003 ClassB
	EN61326-1+A1+A2	FCC Part15 ClassB

<sup>1)</sup> Refer to the working range of the humidity sensor.

<sup>2)</sup> Can easily be changed by software.

\*) The accuracy statement includes the uncertainty of the factory calibration with an enhancement factor k=2 (2-times standard deviation). The accuracy was calculated in accordance with EA-4/02 and with regard to GUM (Guide to the Expression of Uncertainty in Measurement).

## Technical Data for Options EE29/EE31

Display	graphical LC display (128x32 pixels), with integrated push-buttons for selecting parameters and MIN/MAX function		
Alarm outputs	2 x 1 switch contact 250V AC / 6A 28V DC / 6A		
Threshold + hysteresis	can be adjusted with configuration software		
Switching parameters	freely selectable between:	EE29	EE31
	RH	Relative humidity	✓
	T	Temperature	✓
	Td	Dew-point temperature	✓
	Tf	Frost-point temperature	✓
	Tw	Wet-bulb temperature	✓
	e	Water vapour partial pressure	✓
	r	Mixture ratio	✓
	dv	Absolute humidity	✓
	h	Specific enthalpy	✓

## Working range humidity sensor

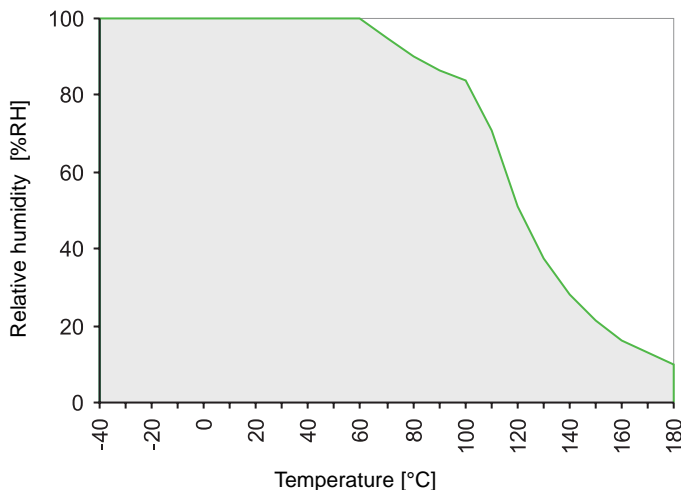

The gray area shows the allowed measurement range for the humidity sensor.

Operating points outside of this range do not lead to destruction of the element, but the specified measurement accuracy cannot be guaranteed.

## Connection diagram

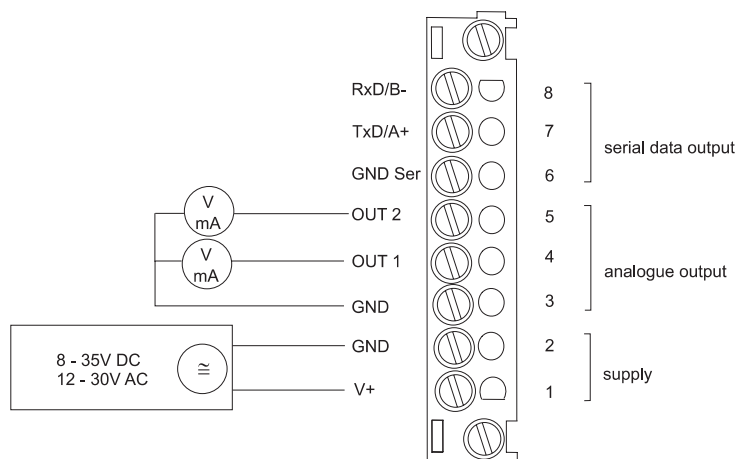

## Terminal configuration - Alarm output

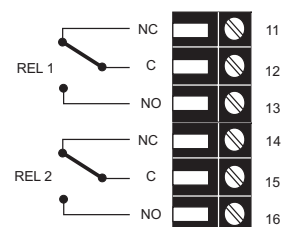

## Ordering Guide EE31

		EE31-	EE31-	EE31-	EE31-	EE31-
<b>Hardware Configuration</b>						
<b>Housing</b>	metal housing	M	M	M	M	M
	polycarbonate housing	P	P	P	P	P
<b>Type</b>	humidity + temperature	FT	FT	FT	FT	FT
<b>Model</b>		A	B	D	E	H
<b>Filter</b>	membrane filter 5mm (0.2")					1
	stainless steel sintered filter	3	3	3	3	
	PTFE filter	5	5	5	5	
	metal grid filter (up to 120°C / 248°F)	6	6	6	6	
	stainless steel grid filter 5mm (0.2")			9	9	7
	stainless steel grid filter (up to 180°C / 356°F)					
<b>Cable length</b> (incl. probe length)	2m (6.6ft)			02	02	02
	5m (16.4ft)			05	05	05
	10m (32.8ft)			10	10	10
	20m (65.6ft)			20	20	20
<b>Probe length</b>	65mm (2.6")			2	2	
	200mm (7.9")		5	5	5	
	400mm (15.8")		6	6	6	
<b>Pressure tight</b>	1/2" male thread					
<b>Feedthrough</b>	1/2" pipe weld joint				HA03	
	1/2" NPT thread				HA05	
					HA07	
<b>Interface</b>	RS232					
	RS485	N	N	N	N	N
	ethernet interface <sup>1)</sup>	E	E	E	E	E
<b>Display</b>	without display					
	with display	D05	D05	D05	D05	D05
<b>Alarm output <sup>2)</sup></b>	without relay					
	with relay	SW	SW	SW	SW	SW
<b>Plug</b>	cable glands					
	1 plug for power supply and outputs	C03	C03	C03	C03	C03
	2 plugs for power supply/outputs and RS232	C07	C07	C07	C07	C07
	2 plugs for power supply/outputs and RS485 Network	C08	C08	C08	C08	C08
<b>Sensing probe</b>	fixed					
	interchangeable			P01	P01	
<b>Coating sensor</b>	no					
	yes	HC01	HC01	HC01	HC01	
<b>Calibration</b>	standard					
	high-humidity calibration		CA01	CA01	CA01	
<b>Supply voltage</b>	8...35V DC / 12...30V AC					
	integrated power supply 100...240V AC, 50/60Hz <sup>3)</sup>	V01	V01	V01	V01	V01
<b>Software Configuration</b>						
<b>Physical parameters of outputs</b>	relative humidity	RH [%]	(A)	Output 1	Select according to Ordering Guide (A - H,J)	
	temperature	T [°C or °F]	(B)	Output 2	Select according to Ordering Guide (A - H,J)	
	dew point temperature	Td [°C or °F]	(C)			
	frost point temperature	Tf [°C or °F]	(D)			
	wet bulb temperature	Tw [°C or °F]	(E)			
	water vapour partial pres.	e [mbar]	(F)			
	mixture ratio	r [g/kg]	(G)			
	absolute humidity	dv [g/m <sup>3</sup> ]	(H)			
	specific enthalpy	h [kJ/kg]	(J)			
<b>Type of output signals</b>	0-5V		(2)	Select according to Ordering Guide (2,3,5,6)		
	0-10V		(3)			
	0-20mA		(5)			
	4-20mA		(6)			
<b>Measured value units</b>	metric / SI			E01	E01	E01
	non metric / US					
<b>Scaling of T-output</b>	-40...60 (T02)	-20...80 (T24)	0...350 (T89)	Output T	Select according to Ordering Guide (Txx)	
<b>Scaling of Td-output in°C or °F</b>	0...50 (T04)	0...180 (T26)	32...120 (T90)	Output Td	Select according to Ordering Guide (Tdxx)	
	0...100 (T05)	-40...180 (T52)	32...140 (T91)			
	0...60 (T07)	-40...100 (T79)	32...180 (T92)			
	-40...120 (T12)	-40...350 (T82)	32...250 (T94)			
	0...120 (T16)	-40...140 (T83)	32...300 (T95)			
	0...80 (T21)	-40...300 (T84)	32...132 (T96)			
	-40...80 (T22)	0...250 (T88)	32...350 (T101)			

1) Combination ethernet and alarm output is not possible / combination ethernet and integrated power supply is not possible

2) Combination alarm output and plugs is not possible (with cable glands only) / combination alarm output and integrated power supply is not possible

3) Integrated power supply includes 2 plugs for power supply and outputs / further plug options are not possible

## Order Example

### EE31-PFTB55SW/BC2-T07-Td03

Housing: polycarbonate housing  
 Type: humidity + temperature  
 Model: duct mounting  
 Filter: PTFE Filter  
 Probe length: 200mm (7.9")  
 Alarm output: yes

Output 1: T  
 Output 2: Td  
 Output signal: 0-5V  
 Scaling of T-output: 0...60°C  
 Scaling of Td-output: -10...50°C

## Ordering Guide EE29

		EE29-	EE29-	EE29-	EE29-
<b>Hardware Configuration</b>					
<b>Housing</b>	metal housing	M	M	M	M
	polycarbonate housing	P	P	P	P
<b>Type</b>	humidity + temperature	FT	FT	FT	FT
<b>Model</b>		A	B	D	E
<b>Filter</b>	stainless steel sintered filter	3	3	3	3
	PTFE Filter	5	5	5	5
	metal grid filter (up to 120°C / 248°F)	6	6	6	6
	stainless steel grid filter (up to 180°C / 356°F)			9	9
<b>Cable length</b> (incl. probe length)	2m (6.6ft)			02	02
	5m (16.4ft)			05	05
	10m (32.8ft)			10	10
	20m (65.6ft)			20	20
<b>Probe length</b>	65mm (2.6")			2	2
	200mm (7.9")		5	5	5
	400mm (15.8")		6	6	6
<b>Pressure tight feedthrough</b>	1/2" male thread				HA03
	1/2" Pipe weld joint				HA05
	1/2" NPT thread				HA07
<b>Display</b>	without display				
	with display	D05	D05	D05	D05
<b>Alarm output <sup>1)</sup></b>	without relay				
	with relay	SW	SW	SW	W
<b>Plug</b>	cable glands				
	1 plug for power supply and outputs	C03	C03	C03	C03
	2 plugs for power supply/outputs and RS232	C07	C07	C07	C07
<b>Sensing probe</b>	fixed				
	interchangeable			P01	P01
<b>Coating sensor</b>	no				
	yes	HC01	HC01	HC01	HC01
<b>Calibration</b>	standard				
	high-humidity calibration		CA01	CA01	CA01
<b>Supply voltage</b>	8...35V DC / 12...30V AC integrated power supply 100...240V AC, 50/60Hz <sup>2)</sup>	V01	V01	V01	V01
<b>Software Configuration</b>					
<b>Physical parameters of outputs</b>	Relative humidity	RH [%] (A)		Output 1	Select according to Ordering Guide (A or B)
	Temperature	T [°C or °F] (B)		Output 2	Select according to Ordering Guide (A or B)
<b>Type of output signals</b>	0-5V	(2)			Select according to Ordering Guide (2,3,5,6)
	0-10V	(3)			
	0-20mA	(5)			
	4-20mA	(6)			
<b>Temperature unit</b>	°C			E01	E01
	°F			E01	E01
<b>Scaling of T-output in °C or °F</b>	-40...60 (T02)	-20...80 (T24)	0...350 (T89)	Output T	Select according to Ordering Guide (Txx) Other T-scaling refer to page 134
	0...50 (T04)	0...180 (T26)	32...120 (T90)		
	0...100 (T05)	-40...180 (T52)	32...140 (T91)		
	0...60 (T07)	-40...100 (T79)	32...180 (T92)		
	-40...120 (T12)	-40...350 (T82)	32...250 (T94)		
	0...120 (T16)	-40...140 (T83)	32...300 (T95)		
	0...80 (T21)	-40...300 (T84)	32...132 (T96)		
	-40...80 (T22)	0...250 (T88)	32...350 (T101)		

1) Combination alarm output and plugs is not possible (with cable glands only) / combination alarm output and integrated power supply is not possible  
2) Integrated power supply includes 2 plugs for power supply and outputs / further plug options are not possible

## Accessories / Replacement Parts

(For further information, see data sheet "Accessories", page 128)

- |  |            |  |            |
|--|------------|--|------------|
| - Filter caps                              | (HA0101xx) | - Bracket for installation onto mounting rails | (HA010203) |
| - Display + housing cover in metal         | (D05M)     | - Drip water protection                        | (HA010503) |
| - Display + housing cover in polycarbonate | (D05P)     | - 1% Calibration                               | (EE90/3H)  |
| - Replacement sensor                       | (Pxx)      | - Calibration set                              | (HA0104xx) |
| - Humidity sensor                          | (FE10)     | - Datalogging and analysis software            | (HA010602) |
| - Interface cable                          | (HA010301) | (for EE31 only)                                |            |
| - Mounting flange                          | (HA010201) | - RS485 Kit (HW + SW) for networking           | (HA010601) |
| - Mounting flange 5mm                      | (HA010208) | (for EE31 only)                                |            |
| (for EE31, model H only)                   |            |  |            |